

PIPE SPECIAL TANDEM AXLE TRAILER

G.V.W.R.	6,000#	AXLES	Two 3500# EZ LUBE w/ 1 Elec. Brake
G.A.W.R. (EA. AXLE)	2,960#	SUSPENSION	Multi-Leaf Spring With Equalizer
COUPLER	2" A-Frame	TIRE	ST205/75-15 Load Range B
SAFETY CHAINS	¼" Grd. 70 w/ Safety Latch Hook (2 ea.)	WHEEL	15 X 5 White Spoke 5 Bolt
JACK	2000# Top Wind (Bolted On)	FLOOR	2" Pine
TONGUE	4" Channel A-Frame	LIGHTS	D.O.T. Stop, Tail, Turn and Clearance
TOP RAIL	2-3/8" Pipe Square Back	ELEC. PLUG	7-Way RV
FRAME	3" X 4" X 1/4" Angle	FINISH (PREP)	Acid Etched w/White Phosphorus, & Two Coats Primer
CROSSMEMBERS	2" X 3" X 3/16" Angle	FINISH	Painted w/ 2 Coats High Solid <i>Supreme</i> Acrylic Automotive Grade Enamel, and Pinstriped
UPRIGHTS	16" Tall 2" X 3" X 3/16" Angle		
FENDERS	9" X 72" Rolled Formed w/ Back		

STANDARD FEATURES

- Two 3500# Axles w/ 1 Electric Brake
- Complete Break-A-Way System w/ Charger
- Lower Jack Support Plate
- Cambered Ez Lube Axles
- 2-3/8" TopRail Capped w/ Self Sealing Plugs
- Rod & Pockets Across Rear
- Safety Chains Attached w/ Cold Rolled Eyelets
- Floor Secured w/ 5/16" Torx Screws

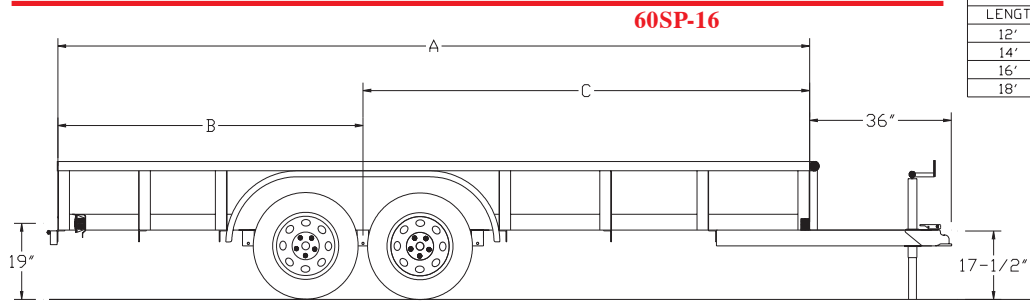

LENGTH	DIMENSIONS		
	A	B	C
12'	145-1/2"	60-1/2"	85"
14'	169-1/2"	66-1/2"	103"
16'	193-1/2"	78-1/2"	115"
18'	217-1/2"	90-1/2"	127"

PRICING

MODEL #	WEIGHT	DESCRIPTION	
60SP-12	1380#	77" X 12' Tandem Axle Trailer	
60SP-14	1450#	77" X 14' Tandem Axle Trailer	
60SP-16	1580#	77" X 16' Tandem Axle Trailer	
60SP-18	1730#	77" X 18' Tandem Axle Trailer	

OPTIONS

Electric Brakes On Two Axles	
Hydraulic Brakes On 1 Axle w/ Atwood Actuator	
Hydraulic Brakes On 2 Axles w/ Atwood Actuator	
4' Slide In Ramps	
Rampgate for 60SP — 4' Tall	
Extra Wide (83" Bed) 102" Overall	
Spare Mount (Side)	
15" Spare Tire & Wheel	
2" Bulldog Coupler	
2-5/16" Atwood Coupler	
2-5/16" Bulldog Coupler	
2K Fold-Up Jack	
Higher Side (Each Additional Foot)	
Enclosed w/ Expanded Metal (Per Sq. Ft.)	
Enclosed w/ Sheet Metal (Per Sq. Ft.) Changes Toprail to 2" Sq. Tube	
1/8" Diamond Plate Floor (Per Sq. Ft.)	
Gas Spring Assist Option For Rampgate	
Fold Back Tongue (14' & Longer)	
Tie Down Pockets (Each)	

Prices Effective January 1, 2005

© 2005 Copyright by Big Tex Trailer Manufacturing, Inc.