

TANDEM AXLE LOW PROFILE GOOSENECK DUMP

G.V.W.R.	14,000#	AXLES	Two 7000# EZ LUBE w/ Elec. Brakes
G.A.W.R. (EA. AXLE)	6400#	SUSPENSION	Multi-Leaf Slipper Spring w/ Equalizer
COUPLER	2-5/16" Standard Adjustable Pipe	TIRE	ST235/85-16 Load Range D
SAFETY CHAINS	3/8" Grd. 70 w/Safety Latch Hook (2 ea.)	WHEEL	16 X 6 HD White Modular 8 Bolt
JACK	10,000# Dropleg (Bolted On)	FLOOR	12 Ga. SmoothSteel
NECK	8" Channel	LIGHTS	D.O.T. Stop, Tail, Turn and Clearance
FRAME	8" Channel	ELEC. PLUG	7-Way RV
CROSSMEMBERS	6" Channel + 3" X 3" Tubing	FINISH (PREP)	Acid Etched w/White Phosphorus, Undercoated w/Panther 813 & Two Coats Primer
BED CROSSMEMBERS	2" X 2" Tubing	FINISH	Painted w/ 2 Coats High Solid <i>Supreme</i> Acrylic Automotive Grade Enamel, and Pinstriped
BED LONG SILS	4" Channel		
BED SIDE RAILS	4" X 6" Formed Angle		
FENDERS	14 Ga. Diamond Plate Double Broke Teardrop		

STANDARD FEATURES

- Complete Break-A-Way System w/ Charge Line
- 36" 12 Ga. Sides w/ Formed Channel Supports
- 1 Piece 12 Ga. Floor
- 45 Degree Dump Angle
- Cambered Ez Lube Axles
- Enclosed Pump & Battery Box Mounted In Front of Bed
- Lockable Control Unit
- Protected Lighting
- Double Rear Gates w/ Cam Latch
- 1/2" Tie Rail On All 4 Sides
- Fully Self Contained Electric Hydraulic Scissor Lift

14GD-14

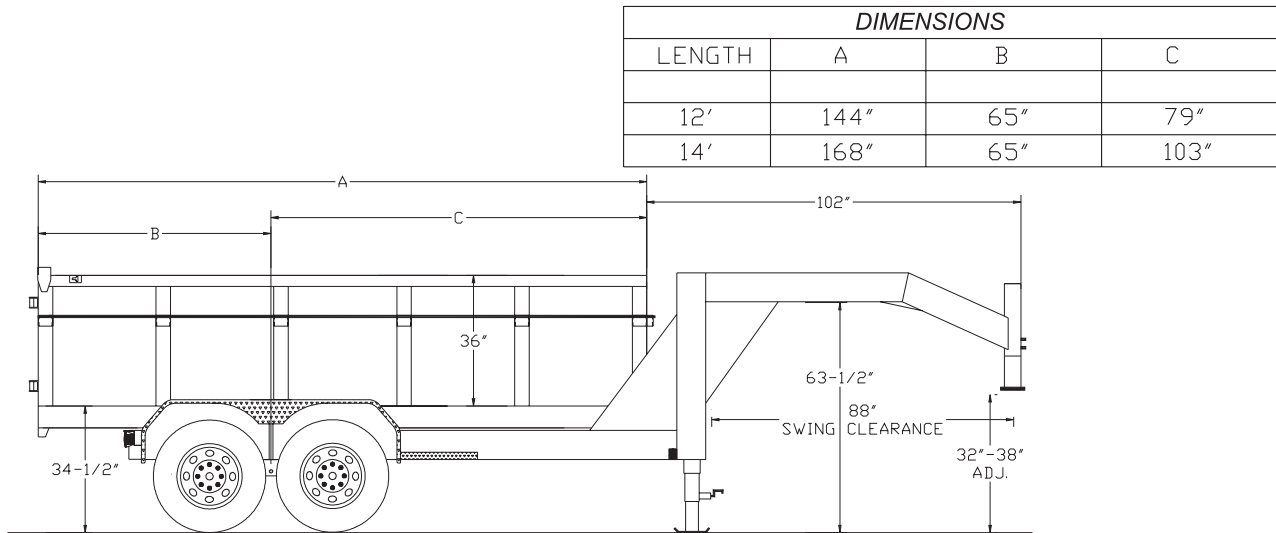

TRAILER WEIGHTS & CAPACITIES

LENGTH	EMPTY WEIGHT	PAYLOAD	BOX CAPACITY
12'	4,295#	9575#	7.75 Cubic Yards
14'	4,570#	9575#	9.05 Cubic Yards

PRICING

MODEL #	DESCRIPTION	
14GD-12	71" X 12' Low Profile Tandem Axle Gooseneck Dump	
14GD-14	71" X 14' Low Profile Tandem Axle Gooseneck Dump	

OPTIONS

16" Spare Tire & Wheel	
7' Slide In Ramps	
16" Tire upgrade to Load Range G	
16' Spare Tire & Wheel - Load Range G	

Prices Effective January 1, 2005

© 2005 Copyright by Big Tex Trailer Manufacturing, Inc.