

TANDEM AXLE LOW PROFILE EXTRA WIDE DUMP

G.V.W.R.	12,000#	AXLES	Two 6000# EZ LUBE w/ Elec. Brakes
G.A.W.R. (EA. AXLE)	6,000#	SUSPENSION	Multi-Leaf Slipper Spring w/ Equalizer
COUPLER	Adjustable 2-5/16" Bulldog	TIRE	ST235/85-16 Load Range D
SAFETY CHAINS	¼" Grd. 70 w/ Safety Latch Hook (2 ea.)	WHEEL	16 X 6 White Spoke 8 Bolt
JACK	7K Dropleg (Bolted On)	FLOOR	12 Ga. Smooth Steel
TONGUE	6" Channel Fold Back	LIGHTS	D.O.T. Stop, Tail, Turn and Clearance
FRAME	6" Channel	ELEC. PLUG	7-Way RV
CROSSMEMBERS	4" - 13# I-Beam	FINISH (PREP)	Acid Etched w/White Phosphorus, Undercoated w/Panther 813 & Two Coats Primer
BED CROSSMEMBERS	2" X 2" Square Tubing 14" oc.	FINISH	Painted w/ 2 Coats High Solid <i>Supreme</i> Acrylic
BED LONG SILS	4" Channel		
BED SIDE RAILS	3" X 6½" Formed Angle		
FENDERS	14 Gauge Diamond Plate Double Broke Teardrop		

STANDARD FEATURES

- Complete Break-A-Way System w/ Charge Line
- 26" 12 Ga. Sides w/ Formed Channel Supports
- 12 Ga. Floor
- Lockable Control Unit
- Enclosed Pump & Battery Box Mounted In Front of Bed
- Protected Lighting
- Double Rear Gates w/ Cam Latch
- 1/2" Tie Rail On All 4 Sides
- 7' Slide in Ramps
- Self Contained Electric Hydraulic Scissor Lift
- 22 Stake Pockets (Sides & Front)
- 45 Degree Dump Angle
- Removable Header Across Rear
- Cambered Ez Lube Axles

12LX-12

DIMENSIONS			
LENGTH	A	B	C
12'	146-3/4"	55-3/4"	94-3/4"

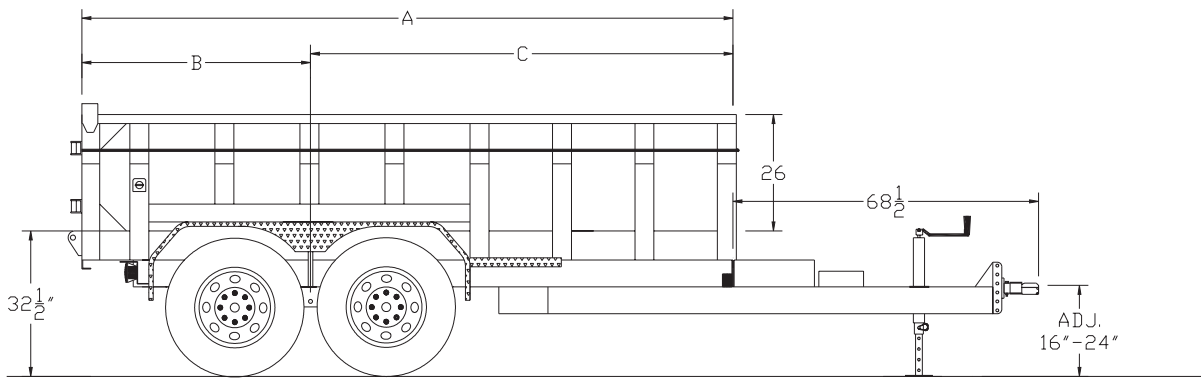

TRAILER WEIGHTS & CAPACITIES

LENGTH	EMPTY WEIGHT	PAYLOAD	BOX CAPACITY
12'	3,880#	8,250#	6.77 Cubic Yards

PRICING

MODEL #	DESCRIPTION
12LX-12	83"X 12' Low Profile Tandem Axle Dump

OPTIONS

Hydraulic Brakes on 2 Axles, 2-5/16" Adjustable Demco Actuator	
Heavy Duty 10K Top Wind Drop Leg Jack	
16" Spare Tire & Wheel	
Spare Tire Mount (on front of bed)	
Adjustable Pintle In Channel	