

TANDEM AXLE LOW PROFILE DUMP

| | | | |
|----------------------------|--|----------------------|---|
| G.V.W.R. | 12,000# | AXLES | Two 6000# EZ LUBE w/ Elec. Brakes |
| G.A.W.R. (EA. AXLE) | 6,000# | SUSPENSION | Multi-Leaf Slipper Spring w/ Equalizer |
| COUPLER | Adjustable 2-5/16" Bulldog | TIRE | ST235/85-16 Load Range D |
| SAFETY CHAINS | 1/4" Grd. 70 w/ Safety Latch Hook (2 ea.) | WHEEL | 16 X 6 White Spoke 8 Bolt |
| JACK | 7000# Top Wind (Bolted On) | FLOOR | 12 Ga. Smooth Steel |
| TONGUE | 6" Channel Fold Back | LIGHTS | D.O.T. Stop, Tail, Turn and Clearance |
| FRAME | 6" Channel | ELEC. PLUG | 7-Way RV |
| CROSSMEMBERS | 4" - 13# I-Beam | FINISH (PREP) | Acid Etched w/White Phosphorus, Undercoated w/Panther 813 & Two Coats Primer |
| BED CROSSMEMBERS | 2" X 2" Square Tubing | FINISH | Painted w/2 Coats High Solid <i>Supreme</i> Acrylic Automotive Grade Enamel, and Pinstriped |
| BED LONG SILS | 4" Channel | | |
| BED SIDE RAILS | 3" X 6 1/2" Formed Angle | | |
| FENDERS | 14 Gauge Diamond Plate Double Broke Teardrop | | |

STANDARD FEATURES

- Complete Break-A-Way System w/ Charge Line
- 26" 12 Ga. Sides w/ Formed Channel Supports
- 1 Piece 12 Ga. Floor
- Lockable Control Unit
- Enclosed Pump & Battery Box Mounted In Front of Bed
- Protected Lighting
- Double Rear Gates w/ Cam Latch
- 1/2" Tie Rail On All 4 Sides
- Cambered Ez Lube Axles
- Self Contained Electric Hydraulic Scissor Lift
- 16 Stake Pockets (Sides & Front)
- 45 Degree Dump Angle
- Removable Header Across Rear

12LP-12

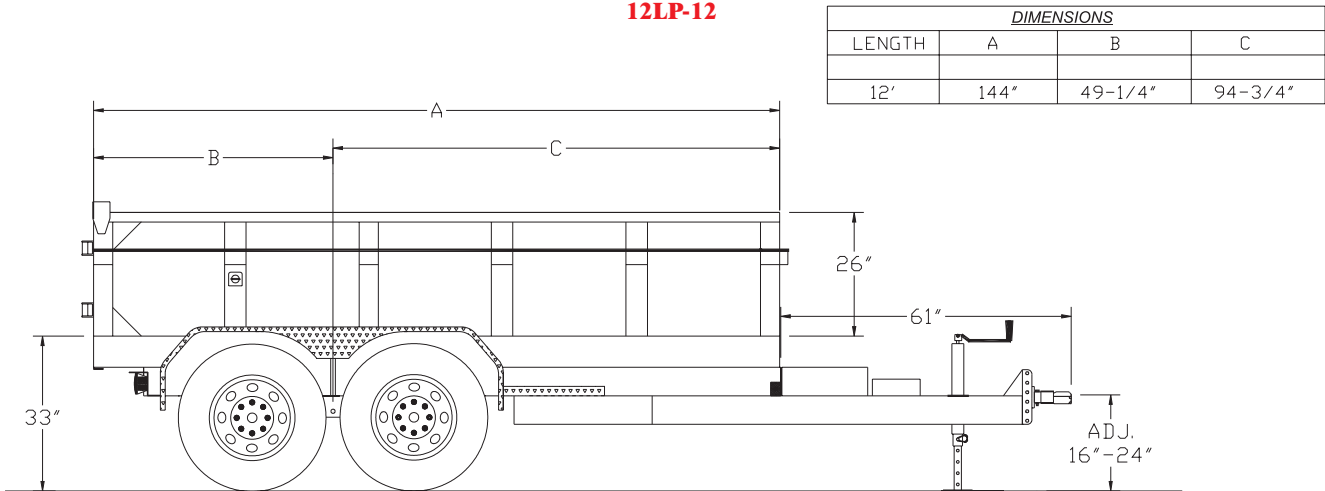

TRAILER WEIGHTS & CAPACITIES

| LENGTH | EMPTY WEIGHT | PAYLOAD | BOX CAPACITY |
|--------|--------------|---------|------------------|
| 12' | 3,660# | 8,250# | 5.64 Cubic Yards |

PRICING

| MODEL # | DESCRIPTION | |
|---------|--|--|
| 12LP-12 | 71" X 12' Low Profile Tandem Axle Dump | |

OPTIONS

| | |
|--|--|
| Hydraulic Brakes on 2 Axles, 2-5/16" Adjustable Demco Actuator | |
| Heavy Duty 10K Top Wind DropLeg Jack | |
| 16" Spare Tire & Wheel | |
| Spare Tire Mount (Side) | |
| 7' Slide In Ramps | |
| Adjustable Pintle In Channel | |

Prices Effective January 1, 2005

© 2005 Copyright by Big Tex Trailer Manufacturing, Inc.