

HEAVY DUTY PIPE TANDEM AXLE TRAILER

G.V.W.R.	9,990#	AXLES	Two 5,200# EZ LUBE w/ Elec. Brakes
G.A.W.R. (EA. AXLE)	5,080#	SUSPENSION	Multi-Leaf Spring w/ Equalizer
COUPLER	2-5/16" Bulldog Coupler	TIRE	ST225/75-15 Load Range D
SAFETY CHAINS	1/4" Grd. 70 w/ Safety Latch Hook (2 ea.)	WHEEL	15 X 6 White Spoke 6 Bolt
JACK	2000# Top Wind (Bolted On)	FLOOR	2" Pine
TONGUE	5" Channel Fold Back	LIGHTS	D.O.T. Stop, Tail, Turn and Clearance
TOP RAIL	2-7/8" Pipe Square Back	ELEC. PLUG	7-Way RV
FRAME	3" X 5" X 1/4" Angle	FINISH (PREP)	Acid Etched w/White Phosphorus, Undercoated w/Panther 813 & Two Coats Primer
CROSSMEMBERS	2" X 3" X 3/16" Angle	FINISH	Painted w/ 2 Coats High Solid <i>Supreme</i> Acrylic Automotive Grade Enamel, and Pinstriped
UPRIGHTS	16" Tall - 2" X 3" X 3/16" Angle		
FENDERS	9" X 72" Teardrop w/ Back		

STANDARD FEATURES

- Two 5200# Cambered Axles w/ 2 Electric Brakes
- Complete Break-A-Way System w/ Charger
- 2-7/8" Pipe Top Rail Capped w/ Self Sealing Plugs
- Safety Chains Attached w/ Cold Rolled Eyelets
- Reflective Marker Tape
- Cambered Ez Lube Axles
- Fold Back Tongue (14' and longer)
- 4" Slide In Ramps (channel)
- Set Back Jack
- Bulldog Forged Coupler
- Floor Secured w/ 5/16" Torx Screws
- Tie Down Pockets, Sides & Rear
- Spare Tire Mount
- Lower Jack Support Plate

DIMENSIONS			
LENGTH	A	B	C
14'	169-1/2"	66-1/2"	103"
16'	193-1/2"	78-1/2"	115"
18'	217-1/2"	90-1/2"	127"
20'	240"	102"	138"

10PI-16

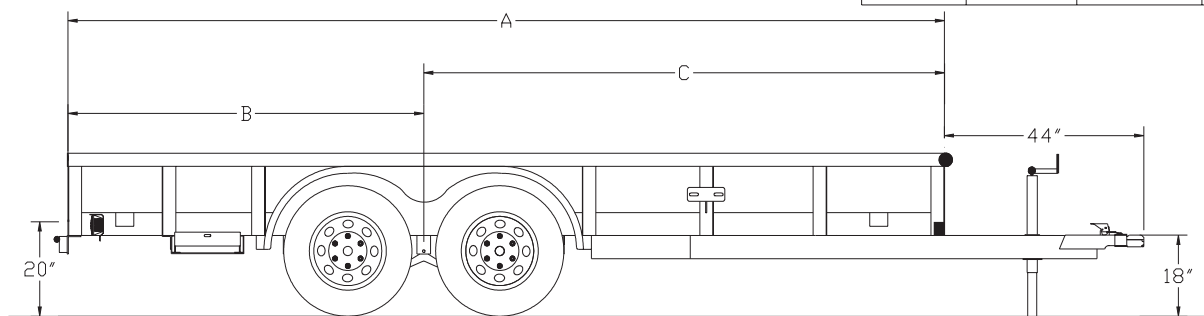

PRICING

MODEL #	WEIGHT	DESCRIPTION
10PI-14	1740#	83" X 14' Tandem Axle Trailer
10PI-16	1920#	83" X 16' Tandem Axle Trailer
10PI-18	2100#	83" X 18' Tandem Axle Trailer
10PI-20	2280#	83" X 20' Tandem Axle Trailer

OPTIONS

Hydraulic Brakes On 1 Axle w/ Adjustable Demco Actuator	
Hydraulic Brakes On 2 Axles w/ Adjustable Demco Actuator	
15" Spare Tire & Wheel - Load Range D	
Drop Leg Jack (7K)	
1/8" Diamond Plate Steel Floor (Per Sq. Ft.)	
Rampgate in lieu of Ramps	
Higher Side (Each Additional Foot)	
Enclosed w/ Expanded Metal (Per Sq. Ft.)	
Enclosed w/ Sheet Metal (Per Sq. Ft.) Changes Toprail to 3" Sq. Tube	
Tire Upgrade to 16" -7.50-16 LR-E	
Spare Tire Upgrade to 16" - 7.50-16 LR-E	
10K Top Wind Drop-Leg Jack	
5' Stand-up Ramp	
Intergrated Ramp Heavy Duty Ramp Gate w/ Gas Spring Assist in Lieu of Ramps	

Prices Effective January 1, 2005