

TANDEM AXLE PAN EQUIPMENT TRANSPORT

G.V.W.R.	9,990#	AXLES	Two 5200# EZ LUBE Torflex Electric Brake
G.A.W.R. (EA. AXLE)	5,080#	SUSPENSION	Torsion
COUPLER	Adjustable 2-5/16" Bulldog	TIRE	ST225D/655D – Load Range D
SAFETY CHAINS	¼" Grd. 70 w/ Safety Latch Hook (2 ea.)	WHEEL	15 X 6 White Spoke 6 Bolt
JACK	2000# Swivel Mount	LIGHTS	D.O.T. Stop, Tail, Turn and Clearance
TONGUE	2" X 4" Square Tubing	ELEC. PLUG	7-Way RV
BED	3/16" Steel Pan	FINISH (PREP)	Acid Etched w/White Phosphorus, Undercoated w/Panther 813 & Two Coats Primer
CROSSMEMBERS	3" Channel	FINISH	Painted w/ 2 Coats High Solid <i>Supreme</i> Acrylic Automotive Grade Enamel, and Pinstriped
FENDERS	10 X 72 Square Broke w/ Teardrop		

STANDARD FEATURES

- Complete Break-A-Way System w/ Battery & Charger
- 1 Piece 3/16" Formed Pan
- Texturized Floor for Increased Traction
- Two 5200# Axles w/ Electric Brakes
- 40" Heavy Duty Fold Up Ramps w/ Expanded Metal
- 78" Inside Dimension
- Cambered Ez Lube Axles
- Fold Up Jack
- Six D-Rings (Inside Pan)
- Safety Chains Secured w/ Cold Rolled Eyelets

10EP-14

DIMENSIONS			
LENGTH	A	B	C
14'	168"	66"	102"
16'	192"	78"	114"

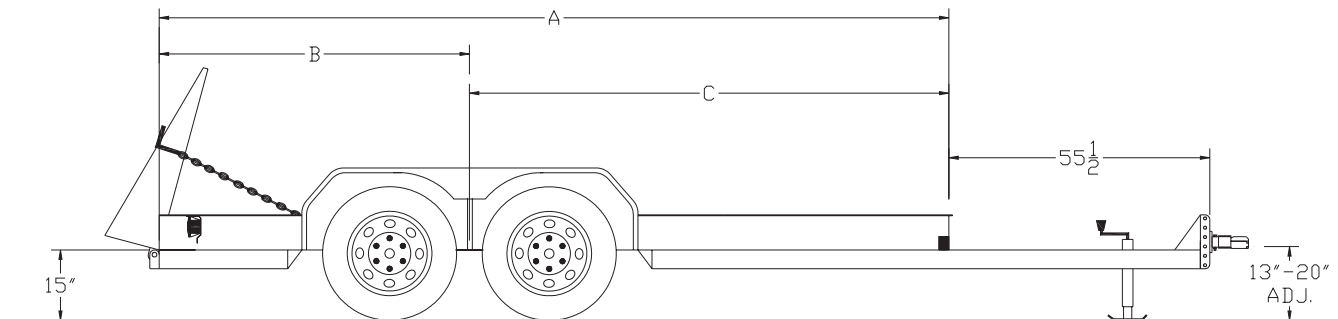

PRICING

MODEL #	WEIGHT	DESCRIPTION	
10EP-14	2,400#	78" X 14' Equipment Transport	
10EP-16	2,500#	78" X 16' Equipment Transport	

OPTIONS

Hydraulic Brakes on 2 Axles, 2-5/16" with Adjustable Demco Actuator	
15" Spare Tire & Wheel – Load Range D	
Tire Upgrade to 16" – 7.50-16 LR-E	
Spare Tire Upgrade to 16" – 7.50-16 LR-E	
Adjustable 3" Pintle	